



Solenoid valve 2/2 way N.O. Direct acting

21A5Z0V45D-OX
÷
21A8Z0V55G-OX

PRESENTATION:

Direct acting S.V. for interception of fluids compatible with the construction materials.

Minimum operational pressure is not required.

The materials used and the tests carried out ensure maximum reliability and duration.

Components, in contact with fluid, oils and greases free and compatible with oxygen for Industrial use.

USE: Automation
Chemical

PIPES: G 3/8 - G 1/2

COILS:

8W - Ø 13	
BDA - BSA	155°C (class F)
BDV	180°C (class H)
12W - Ø 13	
UDA	155°C (class F)
14W - Ø 13	
GDH - GDV	180°C (class H)

COIL HOUSING AND COIL FORMER MATERIAL ARE MADE BY 100% VIRGIN MATERIAL.

Max. allowable pressure (PS) 25 bar

Ambient temperature:

See coils catalogue page for its compatibility.



Gaskets	Temperature		Medium
V=FKM (fluoroelastomer)	- 10°C	+ 60°C	Oxygen

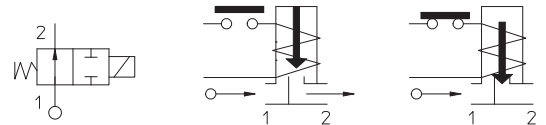

Pipe ISO 228/1	Code	Ø mm	Kv l/mn	Power watt	Pressure			
					min bar	M.O.P.D.		
					AC bar	DC bar		
G 3/8	21A5Z0V45D-OX	4,5	6,5	8	0	4	4	
	21A5Z0V45G-OX			12		6	-	
	14			6		6		
	21A5Z0V55D-OX	8	2,5	2,5				
G 1/2	21A5Z0V55G-OX	5,5	9	12	0	3,5	-	
	14			3,5		3,5		
	21A8Z0V45D-OX	4,5	6,5	8		4	4	
	21A8Z0V45G-OX			12		6	-	
	14			6		6		
	21A8Z0V55D-OX	5,5	9	8		0	2,5	2,5
	21A8Z0V55G-OX			12			3,5	-
	14			3,5			3,5	

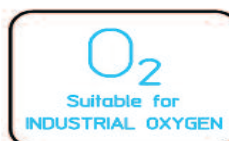

Note Don't use as a safety Valve.

The "ODE" reserves the right to carry out technical and aesthetic modifications without prior notice.

MATERIALS:

Body	Brass - UNI EN 12165 CW617N
Armature tube	Stainless steel AISI series 300
Fixed core	Stainless steel AISI series 400
Plunger	Stainless steel AISI series 400
Phase displacement ring	Copper - Cu 99,9%
Spring	Stainless steel AISI series 300
Seal	V=FKM (compatible with O ₂)
Orifice	Brass - UNI EN 12165 CW617N

On request:	Pg 9 or Pg 11
Connector	ISO 4400
Connector conformity	

FEATURES:

Electrical conformity	IEC 335
Protection degree	IP 65 EN 60529 (DIN 40050) with coil fitted by connector.

SPARE PARTS:

- Coil:**
See coils list

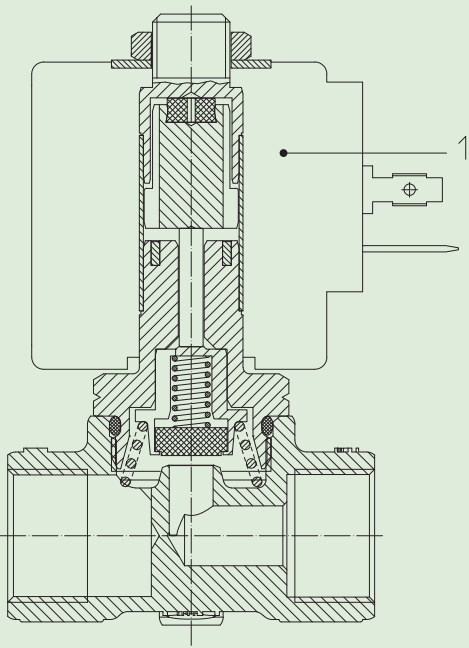

DIMENSIONS:

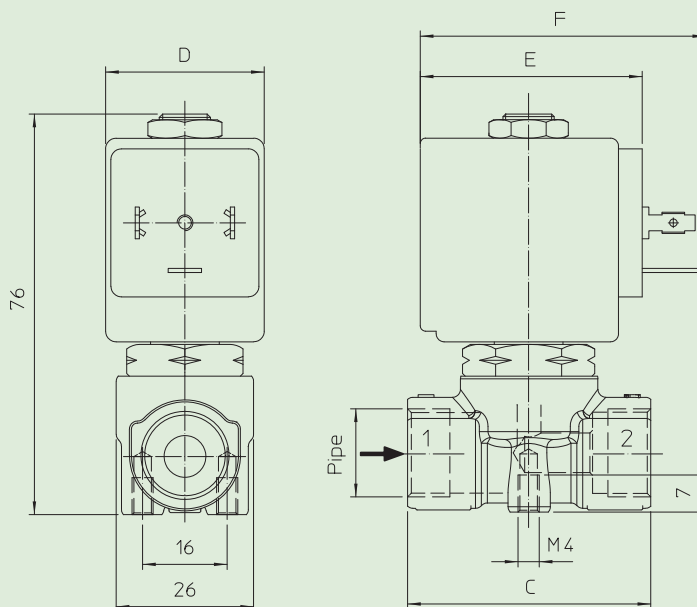

Type	Pipe ISO 228/1	C mm
21A5Z0V	G 3/8	46
21A8Z0V	G 1/2	58

COIL TYPE	POWER ABSORPTION			DIMENSIONS		
	W ==	Hold VA ~	Inrush VA ~	D mm	E mm	F mm
B	8	14,5	25	30	42	54
U	12	23	35	36	48	60
G	14	27	43	52	55	67